

E - 1. 右曲轴箱体  
R. CRANKCASE

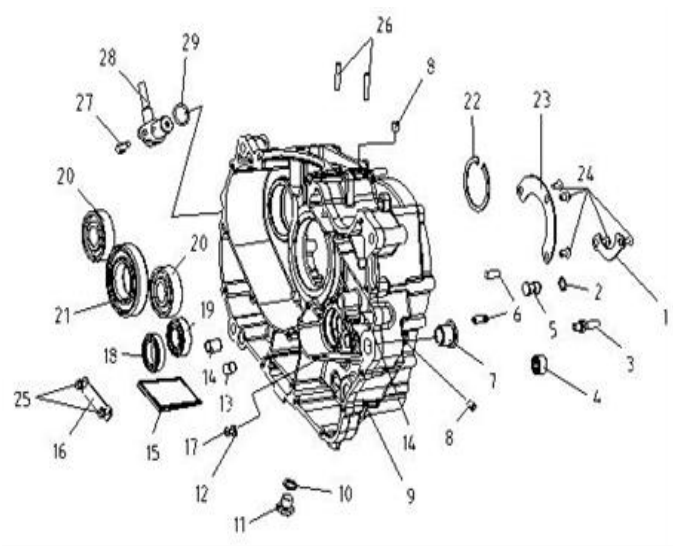

NO..	PART NO..	DESCRIPTION	NO.	PART NO..	DESCRIPTION
E-1-1	11016-F02-0000	BAFFLE PLATE,MAIN SHAFT BEARING	E-1-16	11007-F02-0000	PLATE,DROSS FILTER
E-1-2	90707-F02-0000	CIRCLIP 12	E-1-17	GB\T818-2000	SCREW M5*12-H
E-1-3	23203-F02-0000	BOLT,POSITIONING	E-1-18	92809-F02-0000	BEARING,BALL 6905
E-1-4	92902-F02-0000	NEEDLE BEARING 15*21*12	E-1-19	92804-F02-0000	BEARING,BALL 6004RS
E-1-5	15001-F02-0000	IDLE-GEAR PIN,OIL PUMP	E-1-20	92802-F02-0000	BEARING,BALL 63/22
E-1-6	Q\QD924.1-2003	PIN,ADJUSTING 92401-08020	E-1-21	92801-F02-0000	BEARING,BALL 6208
E-1-7	11011-F02-0000	BUSH, DAMPING	E-1-22	90710-F02-0000	CIRCLIP 56
E-1-8	GB/T77-2000	SCREW M8*10-6g	E-1-23	11013-F02-0000	BAFFLE PLATE,MAIN BEARING
E-1-9	1110A-F02-0000	R.CRANKCASE COMB.	E-1-24	GB/T819.1-2000	SCREW M6*12-H
E-1-10	90601-F02-0000	WASHER 14*19*1.75	E-1-25	Q\QD922-2003	BOLT,FLANG 92140-06012A
E-1-11	11015-F02-0000	BOLT,DRAIN PLUG M14*12	E-1-26	Q\QD921-2002	BOLT, STUD 92120-6301015-110
E-1-12	11014-F02-0000	BEARING PLATE,GEARSHIFT DRUM	E-1-27	GB\T70.1-2000	BOLT M6*16
E-1-13	GB/T77-2000	SCREW M12*16-6g	E-1-28	39110-F02-0000	ROTATIONAL SPEED SENSOR,CRANK SHAFT
E-1-14	90803-F02-0000	PIN,POSITIONING 92401-13018	E-1-29	91204-F02-0000	O-RING 17*2
E-1-15	15122-F02-0000	OIL FILTER			

E - 2. 左曲轴箱体  
L.CRANKCASE

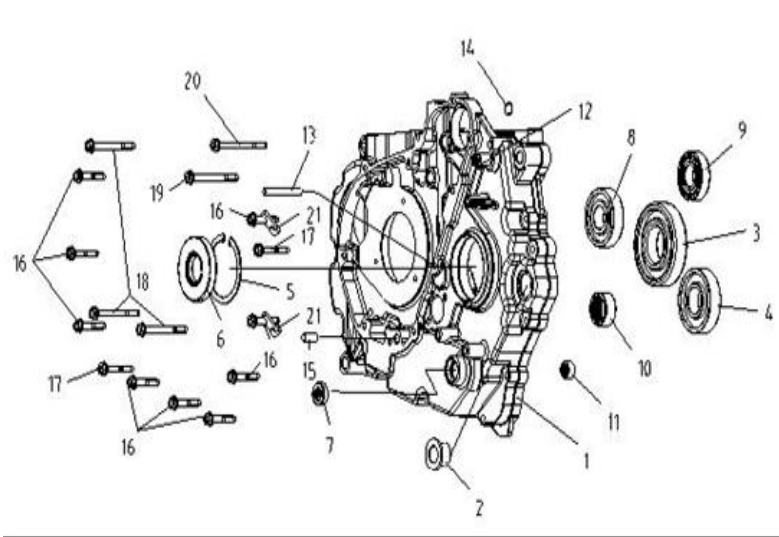

NO.	PART NO..	DESCRIPTION	NO.	PART NO..	DESCRIPTION
E-2-1	1120A-F02-0000	L.CRANKCASE COMB.	E-2-16	Q\QD920-2002	BOLT, FLANGE 95801-06040-20
E-2-2	11011-F02-0000	BUSH, DAMPING	E-2-17	Q\QD920-2002	BOLT, FLANGE 95801-06050-20
E-2-3	92803-F02-0000	BEARING, BALL 6307	E-2-18	Q\QD920-2002	BOLT, FLANGE 95801-06070-20
E-2-4	92805-F02-0000	BEARING, BALL 6305	E-2-19	Q\QD922-2003	BOLT, FLANGE 92140-06075
E-2-5	90709-F02-0000	CIRCLIP 62	E-2-20	Q\QD920-2002	BOLT, FLANGE 95801-06080-20
E-2-6	91101-F02-0000	OIL-SEAL 25*62*11	E-2-21	12005-B01-0000	RETAINING CLIP, WIRE HARNESS
E-2-7	91105-F02-0000	OIL-SEAL 12*22*7			
E-2-8	92802-F02-0000	BEARING, BALL 63/22			
E-2-9	92806-F02-0000	BEARING, BALL 6204-RS			
E-2-10	92903-F02-0000	BEARING, NEEDLE 25*32*16			
E-2-11	92905-F02-0000	BEARING, NEEDLE 12*16*10			
E-2-12	11203-F02-0000	JOINT, VENTIDUCT PIPE			
E-2-13	Q\QD921-2002	BOLT, STUD 92120-6601021-110			
E-2-14	GB/T77-2000	SCREW M8*10-6g			
E-2-15	Q\QD924.1-2003	PIN, ADJUSTING 92401-08020			

E - 3. 右曲轴箱盖、机油虑芯  
R. CRANKCASE COVER &

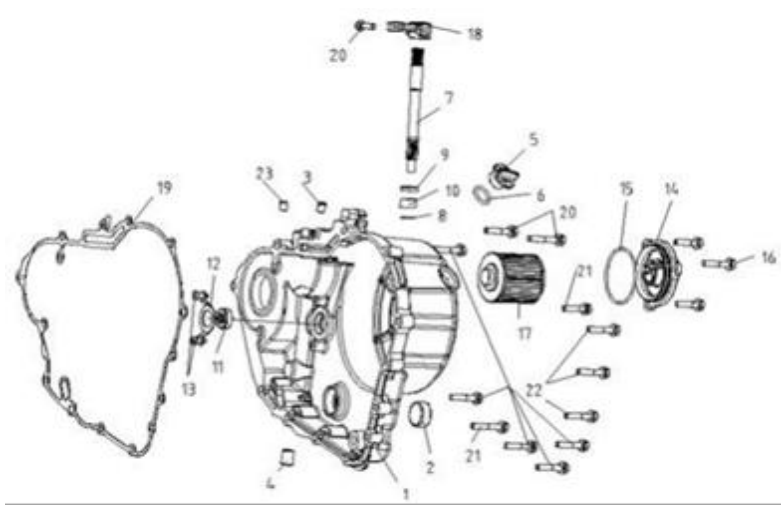

NO.	PART NO..	DESCRIPTION	NO.	PART NO..	DESCRIPTION
E-3-1	11301-F02-0000	R. CEANKCASE COVER	E-3-16	Q\QD920-2002	BOLT, STUD 95801-06025-20
E-3-2	1132A-F02-0000	PEEP HOLE COMB.	E-3-17	15200-F02-0000	OIL FILLTER COMB.
E-3-3	GB/T77-2000	SCREW M8*10-6g	E-3-18	11342-F02-0000	ARM, CLUTCH
E-3-4	GB/T77-2000	SCREW M12*16-6g	E-3-19	11017-F02-0000	SEAL,R.CRANKCASE COVER
E-3-5	11311-F02-0000	OIL FILLING PLUG	E-3-20	Q\QD920-2002	BOLT,FALNGE 95801-06028-20
E-3-6	91205-F02-0000	O-RING 17*3	E-3-21	Q\QD920-2002	BOLT, FLANGE 95801-06040-20
E-3-7	11341-F02-0000	LEVER,CLUTCH	E-3-22	Q\QD920-2002	BOLT, FLANGE 95801-06030-20
E-3-8	90703-F02-0000	CIRCLIP 7	E-3-23	GB/T77-2000	SCREW M10*10-6g
E-3-9	91102-F02-0000	OIL-SEAL 12*18*5	E-3-24		
E-3-10	92905-F02-0000	BEARING, NEEDLE 12*16*10	E-3-25		
E-3-11	91105-F02-0000	OIL-SEAL 12*22*7	E-3-26		
E-3-12	11331-F02-0000	PLATE, OIL-SEAL	E-3-27		
E-3-13	GB\T818-2000	SCREW M5*12-H	E-3-28		
E-3-14	11332-F02-0000	COVER,OIL FILTER	E-3-29		
E-3-15	91206-F02-0000	O-RING 58*2.5			

E - 4. 曲柄、连杆、活塞  
CRANKCONNECTING

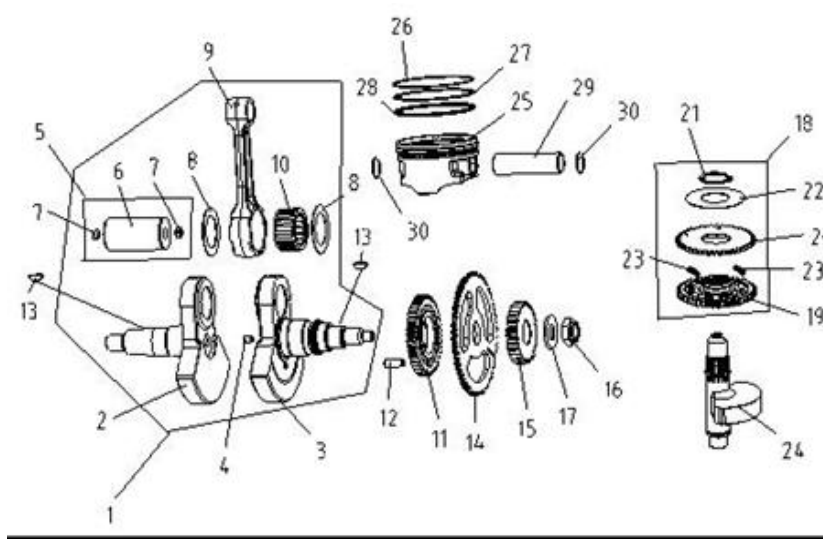

NO.	PART NO..	DESCRIPTION	NO.	PART NO..	DESCRIPTION
E-4-1	13000-F02-0000	CRANK SHAFT AND CONNECTING ROD COMB.	E-4-16	90304-F02-0000	NUT M18
E-4-2	13211-F02-0000	L. CRANKSHAFT	E-4-17	90626-F02-0000	WASHER 18.5
E-4-3	13212-F02-0000	R. CRANKSHAFT	E-4-18	1331A-F02-0000	DRIVEN GEAR COMB., BALANCE SHAFT
E-4-4	13217-F02-0000	NOZZLE	E-4-19	13311-F02-0000	DRIVEN GEAR I, BALANCE SHAFT
E-4-5	1322A-F02-0000	PIN COMP., CRANKSHAFT	E-4-20	13312-F02-0000	DRIVEN GEAR II, BALANCE SHAFT
E-4-6	13221-F02-0000	PIN,CRANKSHAFT	E-4-21	90701-F02-0000	CIRCLIP 32
E-4-7	13222-F02-0000	PLUG	E-4-22	13314-F02-0000	WASHER,DISK SHAPE
E-4-8	13213-F02-0000	WASHER	E-4-23	13313-F02-0000	DRIVEN GEAR SPRING, BALANCE SHAFT
E-4-9	13216-F02-0000	CONNECTING ROD	E-4-24	13302-F02-0000	BALANCE SHAFT
E-4-10	13214-F02-0000	BEARING, NEEDLE	E-4-25	13101-F02-0000	PISTON
E-4-11	13301-F02-0000	DRIVING GEAR,BALANCE SHAFT	E-4-26	13111-F02-0000	PISTON RING A
E-4-12	90802-F02-0000	PIN, ADJUSTING 8*22	E-4-27	13112-F02-0000	PISTON RING B
E-4-13	13001-F02-0000	SEMI KEY	E-4-28	13120-F02-0000	OIL RING
E-4-14	13002-F02-0000	FLUTED DISK,SPEED SENSOR	E-4-29	13102-F02-0000	PIN, PISTON
E-4-15	22101-F02-0000	DRIVING GEAR,PRIMARY	E-4-30	13107-F02-0000	CIRCLIP, PISTON PIN

E - 5. 左前盖、定子组合  
L. FR COVER \ STATOR

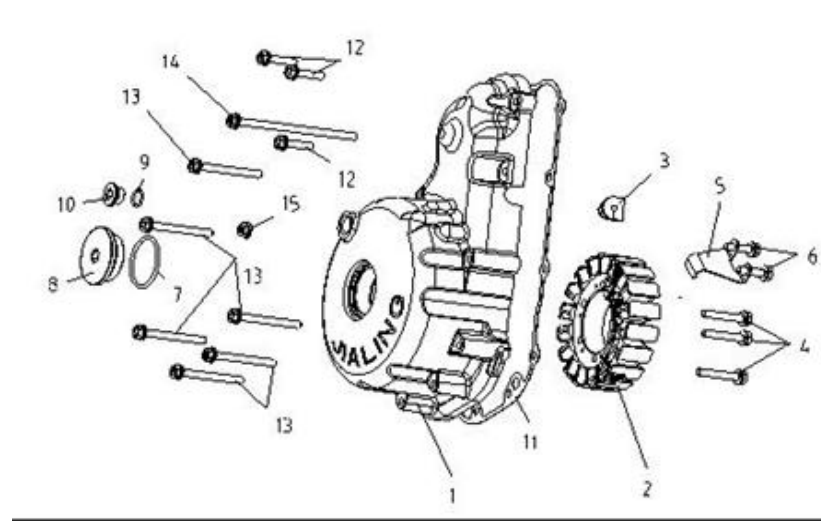

NO.	PART NO..	DESCRIPTION			
E-5-1	11401-F02-0000	L. FR COVER			
E-5-2	31120-F02-0000	STATOR COMB.			
E-5-3	31131-F02-0000	CABLE GROMMET			
E-5-4	Q\QD922-2003	BOLT, FLANGE 92140-06035			
E-5-5	11004-F02-0000	PLATE,WIRENESS FIXTURE			
E-5-6	Q\QD922-2003	BOLT, FLANGE 92140-06018			
E-5-7	91212-F02-0000	O-RING 40*2.5			
E-5-8	1102A-F02-0000	COVER,PEEP HOLE			
E-5-9	91213-F02-0000	O-RING 12.42*178			
E-5-10	11002-F02-0000	UPPER COVER,PEEP HOLE			
E-5-11	11402-F02-0000	SEAL,FR COVER L.			
E-5-12	Q\QD920-2002	BOLT, FLANGE 95801-06025-20			
E-5-13	Q\QD920-2002	BOLT, FLANGE 95801-06055-20			
E-5-14	Q\QD920-2002	BOLT, FLANGE 95801-06105-20			
E-5-15	GB\T6177.1-2000	NUT M6			

E - 6-1. 气缸头、凸轮轴

CYLINDER HEAD \

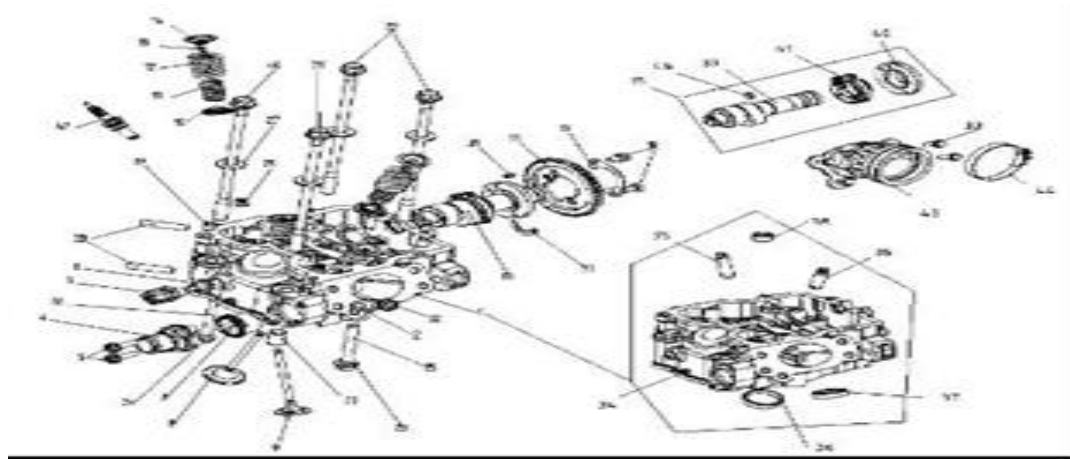

NO.	PART NO..	DESCRIPTION	NO.	PART NO..	DESCRIPTION
E-6-1	1220A-F02-0000	CYLINDER HEAD COMB.	E-6-16	14303-F02-0000	SPROCKET DRIVEN, TIMMING CHAIN
E-6-2	90613-F02-0000	WASHER 8	E-6-17	14304-F02-0000	FIXING PLATE, SPROCKET DRIVEN TIMING CHAIN
E-6-3	1941A-F02-0000	THERMOSTAT	E-6-18	GB\T5783-2000	BOLT M6*10
E-6-4	19006-F02-0000	COVER, THERMOSTAT	E-6-19	Q\QD924.1-2003	PIN, POSITIONING 92401-08012
E-6-5	Q\QD920-2002	BOLT, FLANGE 95801-06022-20	E-6-20	90803-F02-0000	PIN, POSITIONING 92401-13018
E-6-6	90601-F02-0000	WASHER 14*19*1.75	E-6-21	11012-F02-0000	BOLT, CYLINDER M10*190.CYLINDER
E-6-7	39130-F02-0000	SENSOR, WATER TEMPERATURE	E-6-22	11005-F02-0000	BOLT, CYLINDER M10*203.CYLINDER
E-6-8	14711-F02-0000	VALVE, INLET	E-6-23	GB\T6177.1-2000	BOLT M8
E-6-9	14712-F02-0000	VALVE, OUTLET	E-6-24	GB\T6177.1-2000	BOLT M6
E-6-10	14702-F02-0000	SPRING SEAT, LOWER	E-6-25	Q\QD921-2002	BOLT, STUD 92120-8651421-110
E-6-11	14703-F02-0000	SPRING, VALVE IN	E-6-26	Q\QD921-2002	BOLT, STUD 92120-6601021-110
E-6-12	14704-F02-0000	SPRING, VALVE OUT	E-6-27	90624-F02-0000	WASHER 10
E-6-13	14701-F02-0000	CLIP, CLOCK	E-6-28	Q\QD921-2002	BOLT, STUD 92120-8341414-110
E-6-14	14707-F02-0000	UPPER, SPRING SEAT	E-6-29	14705-F02-0000	SEAL, VALVE STEM
E-6-15	1411A-F02-0000	CAMSHAFT COMB.	E-6-30	14118-F02-0000	BLOCK RING, CAMSHAFT

E - 6-2. 气缸头、凸轮轴

CYLINDER HEAD \

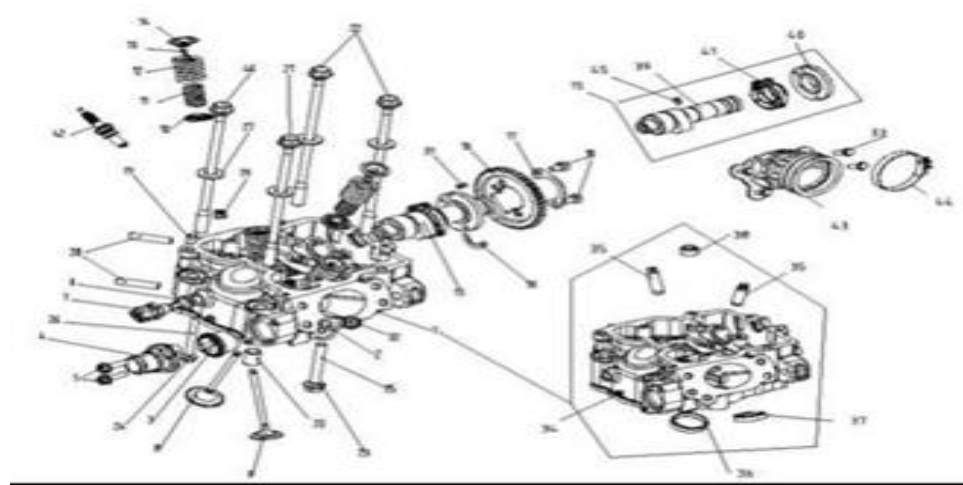

NO.	PART NO..	DESCRIPTION	NO.	PART NO..	DESCRIPTION
E-6-31	Q\QD924.1-2003	PIN, POSITIONING 92403-05008	E-6-46	11012-F02-0000	BOLT, CYLINDER M10*195
E-6-32	Q\QD920-2002	BOLT, FLANGE 95801-08012-20			
E-6-33	Q\QD920-2002	BOLT, FLANGE 95801-08018-20			
E-6-34	12201-F02-0000	CYLINDER HEAD			
E-6-35	12213-F02-0000	PIPE, VALVE			
E-6-36	12222-F02-0000	SEAT, VALVE IN			
E-6-37	12223-F02-0000	SEAT, VALVE OUT			
E-6-38	12205-F02-0000	CORE PLUG			
E-6-39	14111-F02-0000	CAMSHAFT			
E-6-40	14112-F02-0000	FLANGE, CAMSHAFT			
E-6-41	14150-F02-0000	REDUCTOR COMB.			
E-6-42	33300-F02-0000	SPARK PLUG			
E-6-43	1241A-F02-0000	PIPE COMB., VALVE IN			
E-6-44	1713A-F02-0000	CLIP COMP.			
E-6-45	14157-F02-0000	PIN, ADJUSTING			

E - 7.  
CYLINDER \ ROCKER

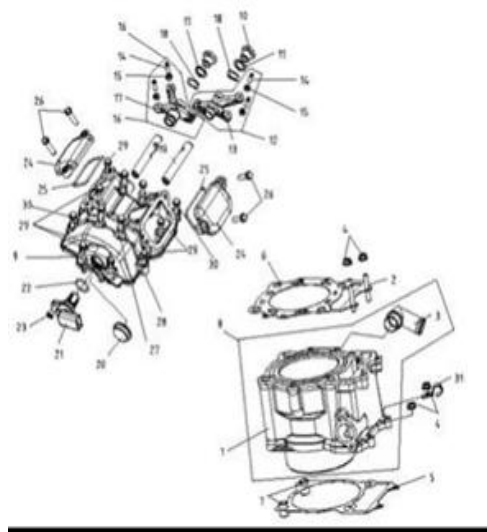

NO.	PART NO..	DESCRIPTION	NO.	PART NO..	DESCRIPTION
E-7-1	1211A-F02-0000	CYLINDER	E-7-16	1441A-F02-0000	ROCKER ARM COMB.,VALVE IN
E-7-2	Q\QD921-2002	BOLT, STUD 92120-6381215-110	E-7-17	14413-F02-0000	ROCKER ARM,VALVE IN
E-7-3	12112-F02-0000	JOINT,WATER PIPE	E-7-18	90621-F02-0000	WASHER,RIPPLE
E-7-4	GB\T6177.1-2000	NUT M6	E-7-19	14404-F02-0000	ROCKER SHAFT
E-7-5	12009-F02-0000	GASKET,CYLINDER	E-7-20	9123A-F02-0000	END COVER, CAMSHAFT
E-7-6	1207A-F02-0000	GASKET,CYLINDER	E-7-21	39120-F02-0000	PHASE SENSOR
E-7-7	90803-F02-0000	PIN,POSITIONING 92401-13018	E-7-22	91204-F02-0000	O-RING 17*2
E-7-8	12100-F02-0000	CYLINDER COMB.	E-7-23	GB\T70.1-2000	BOLT M6*16
E-7-9	12311-F02-0000	COVER,CYLINDER HEAD	E-7-24	12301-F02-0000	CAP,VALVE
E-7-10	12302-F02-0000	COVER,ROCKER SHAFT	E-7-25	91209-F02-0000	SEAL, VALVE CAP
E-7-11	91207-F02-0000	SEAL,ROCKER SHAFT	E-7-26	Q\QD922-2003	BOLT,FLANGE 92140-06022B
E-7-12	1442A-F02-0000	ROCKER ARM COMB.,EX VALVE	E-7-27	90622-F02-0000	WASHER
E-7-13	14423-F02-0000	ROCKER ARM,EX VALVE	E-7-28	Q\QD920-2002	BOLT, FLANGE 92801-06055-20
E-7-14	14401-F02-0000	SCREW,VALVE ADJUSTING	E-7-29	Q\QD922-2003	BOLT, FLANGE 92140-06030B-10
E-7-15	14402-B01-0000	NUT,VALVE ADJUSTING	E-7-30	Q\QD922-2003	BOLT, FLANGE 92140-06032B-10
E-7-31	12001-F02-0000	CORD, CLUTCH CABLE			



E - 8. 变速鼓、拨叉、变速轴  
 DRUM, GEARSHIFT \ FORK

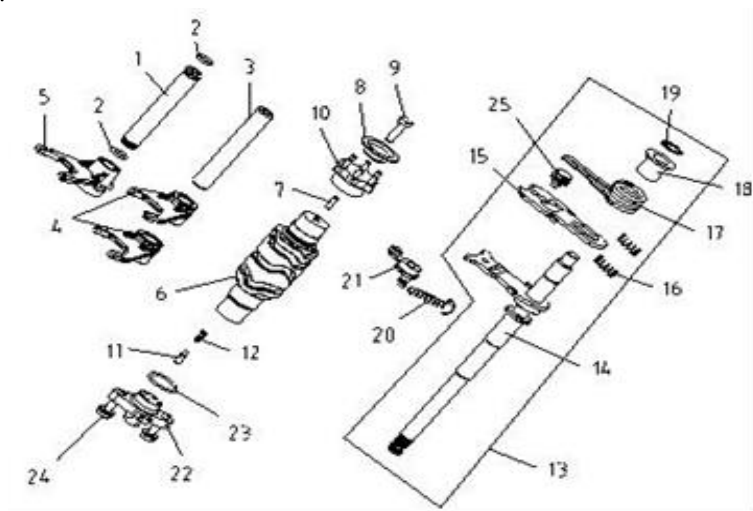

NO.	PART NO..	DESCRIPTION	NO.	PART NO..	DESCRIPTION
E-8-1	23131-F02-0000	AXLE, FORK I	E-8-16	23303-F02-0000	SPRING,PRESSING
E-8-2	91211-F02-0000	O-RING 10*2	E-8-17	23302-F02-0000	SPRING RETURN, GEARSHIFT SHAFT
E-8-3	23132-F02-0000	AXLE, FORK II	E-8-18	23304-F02-0000	SLEEVE, GEARSHIFT SHAFT
E-8-4	23101-F02-0000	FORK II	E-8-19	90704-F02-0000	CIRCLIP 14
E-8-5	23121-F02-0000	FORK I	E-8-20	23301-F02-0000	SPRING RETURN, PLATE POSITIONING
E-8-6	23201-F02-0000	DRUM,GEARSHIFT	E-8-21	23310-F02-0000	PLATE POSITIONING COMP., DRUM,GEARSHIFT
E-8-7	23023-F02-0000	PIN B4*12	E-8-22	37120-F02-0000	SWITCH,GEARS
E-8-8	23202-F02-0000	DISK,RESTRICTING	E-8-23	91208-F02-0000	O-RING 20*2.5
E-8-9	GB\T5783-2000	BOLT M6*20	E-8-24	Q\QD920-2002	BOLT, FLANGE 95801-06022-20
E-8-10	2321A-F02-0000	PLATE COMB.	E-8-25	23323-F02-0000	PIN SHAFT,RESTRICTING
E-8-11	23021-F02-0000	CONTACT PIN			
E-8-12	23022-F02-0000	SPRING,MOVING CONTACT			
E-8-13	2333A-F02-0000	PLATE COMB., GEARSHIFT SHAFT			
E-8-14	2332A-F02-0000	GEARSHIFT SHAFT COMB.			
E-8-15	23305-F02-0000	PLATE, GLIDING			

E - 9. 起动机、转子组合  
ELECTRIC STARTER,

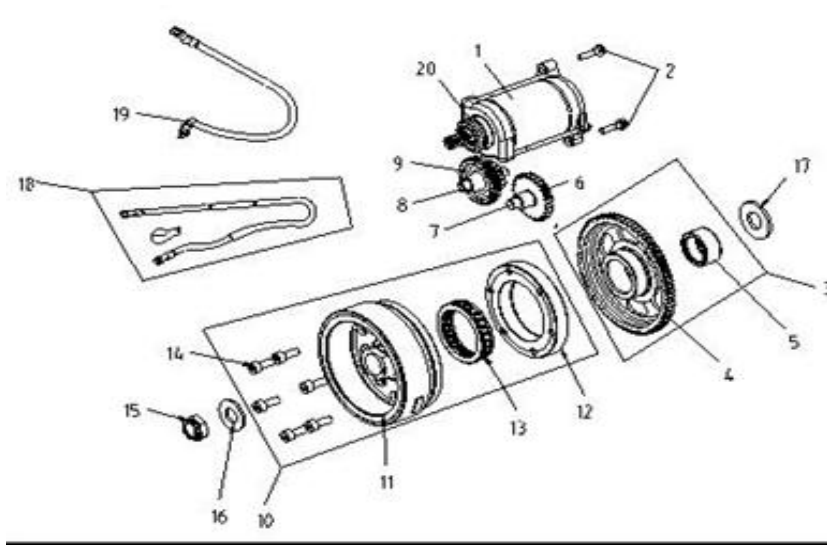

NO.	PART NO..	DESCRIPTION	NO.	PART NO..	DESCRIPTION
E-9-1	31200-F02-0000	ELECTRIC STARTER COMP.	E-9-16	90626-F02-0000	WASHER 18.5
E-9-2	Q\QD920-2002	BOLT, FLANGE 95801-06025-20	E-9-17	90627-F02-0000	WASHER 35.3
E-9-3	2440A-F02-0000	GEARS COMB.,DISK	E-9-18	3413A-F02-0000	CONNECTOR WIRE,ELECTRIC STARTER
E-9-4	24403-F02-0000	GEARS, DISK	E-9-19	3414A-F02-0000	EARTH WIRE,ELECTRIC STARTER
E-9-5	92904-F02-0000	BEARING, NEEDLE 32*42*20	E-9-20	31202-F02-0000	O-RING 34*3
E-9-6	24502-F02-0000	GEAR,IDLING			
E-9-7	24501-F02-0000	TRANSMISSION SHAFT I			
E-9-8	24504-F02-0000	TRANSMISSION SHAFT II			
E-9-9	24503-F02-0000	GEAR,DUAL ARTICULATED			
E-9-10	3111P-F02-0000	FLYWING WHEEL COMB.			
E-9-11	31110-F02-0000	ROTOR COMB.			
E-9-12	24313-F02-0000	OUTER, UNITARY			
E-9-13	2431A-F02-0000	CLUTCH COMP.,STARTER			
E-9-14	GB\T70.1-2000	SCREW, HEX M8*20			
E-9-15	90304-F02-0000	NUT M18			

E-10. 水泵、油泵

WATER PUMP \ OIL PUMP

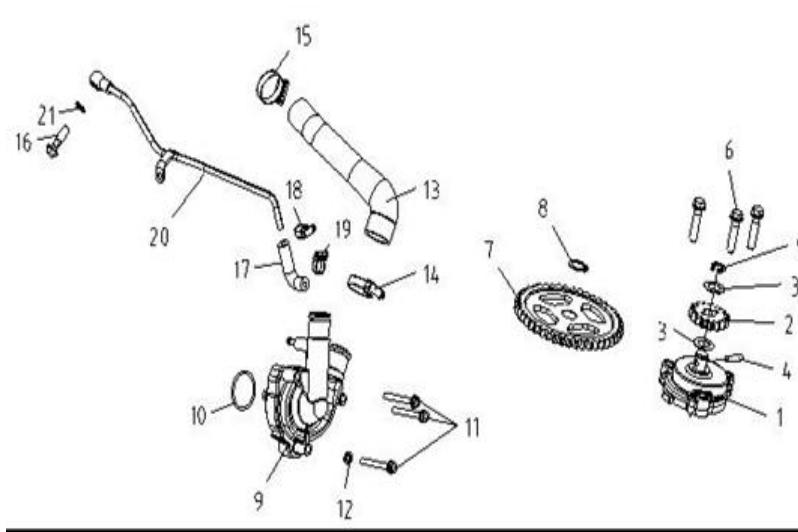

NO.	PART NO..	DESCRIPTION	NO.	PART NO..	DESCRIPTION
E-10-1	15110-F02-0000	OIL PUMP COMP.	E-10-16	19004-F02-0000	FIXTURE BOLT, WATER PIPE
E-10-2	15116-F02-0000	DRIVEN GEAR,OIL PUMP	E-10-17	19012-F02-0000	WATER PIPE H
E-10-3	90618-F02-0000	WASHER 10.5	E-10-18	91404-F02-0000	RING C, CLAMP
E-10-4	Q\QD924.1-2003	PIN, ADJUSTING 92403-04016	E-10-19	91406-F02-0000	RING E, CLAMP
E-10-5	90702-F02-0000	CIRCLIP 10	E-10-20	1902A-F02-0000	WATER PIPE COMB. MINO RECYCLING
E-10-6	Q\QD922-2003	BOLT, FLANGE 92140-06025B	E-10-21	90435-F02-0000	WASHER A, OIL PIPE JOINT
E-10-7	15011-F02-0000	CENTER GEAR,OIL PUMP			
E-10-8	90707-F02-0000	CIRCLIP 12			
E-10-9	19700-F02-0000	WATER PUMP COMP.			
E-10-10	91203-F02-0000	O-RING 38.8*2.4			
E-10-11	Q\QD920-2002	BOLT, FLANGE 95801-06065-20			
E-10-12	90622-F02-0000	WASHER			
E-10-13	19002-F02-0000	WATER PIPE B			
E-10-14	91403-F02-0000	RING B, CLAMP			
E-10-15	91405-F02-0000	RING D, CLAMP			



E-12-1. 变速机构  
GEARSHIFT

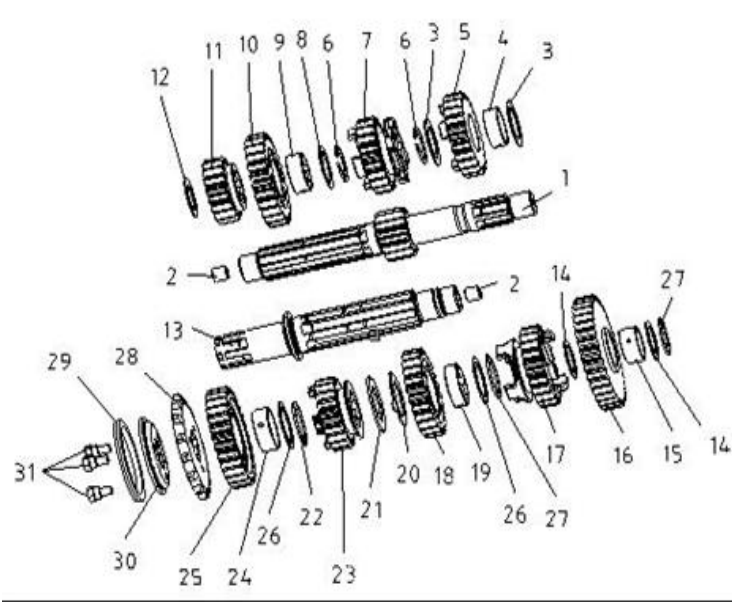

NO.	PART NO..	DESCRIPTION	NO.	PART NO..	DESCRIPTION
E-12-1	22201-F02-0000	MAIN SHAFT,TRANSMISSION	E-12-16	22312-F02-0000	1ST GEAR , DRIVEN
E-12-2	22203-F02-0000	NOZZLE, OIL 10	E-12-17	22342-F02-0000	4TH GEAR , DRIVEN
E-12-3	90608-F02-0000	WASHER 25.2	E-12-18	22332-F02-0000	3RD GEAR , DRIVEN
E-12-4	22343-F02-0000	COLLAR,4TH DRIVING GEAR	E-12-19	22333-F02-0000	COLLAR , 3RD GEAR DRIVEN
E-12-5	22341-F02-0000	4TH GEAR,DRIVING	E-12-20	90614-F02-0000	WASHER,SPLINE II
E-12-6	90708-F02-0000	CIRCLIP 25	E-12-21	90615-F02-0000	WASHER,SPLINE III
E-12-7	22331-F02-0000	3RD GEAR,DRIVING	E-12-22	90706-F02-0000	CIRCLIP28
E-12-8	90609-F02-0000	WASHER,SPLINE I	E-12-23	22352-F02-0000	5TH GEAR , DRIVEN
E-12-9	22353-F02-0000	COLLAR,5TH GEAR DRIVING	E-12-24	22323-F02-0000	COLLAR , 2ND GEAR DRIVEN
E-12-10	22351-F02-0000	5TH GEAR,DRIVING	E-12-25	22322-F02-0000	2ND GEAR , DRIVEN
E-12-11	22321-F02-0000	2ND GEAR,DRIVING	E-12-26	90616-F02-0000	WASHER , 28.2
E-12-12	90611-F02-0000	WASHER 20.2	E-12-27	90705-F02-0000	CIRCLIP 22
E-12-13	22202-F02-0000	COUNTER SHAFT,TRANSMISSION	E-12-28	22401-F02-0000	SPROCKET , DRIVING
E-12-14	90612-F02-0000	WASHER 22.2	E-12-29	22403-F02-0000	RUBBER RING , DAMPING
E-12-15	22313-F02-0000	COLLAR , 1ST DRIVEN GEAR	E-12-30	22402-F02-0000	FIXTURE PLATE , SPROCKET DRIVING
			E-12-31	22404-F02-0000	BOLT M6, SHAFT

E-13. 张紧器、正时链条  
TENTIONER \ TIMMING

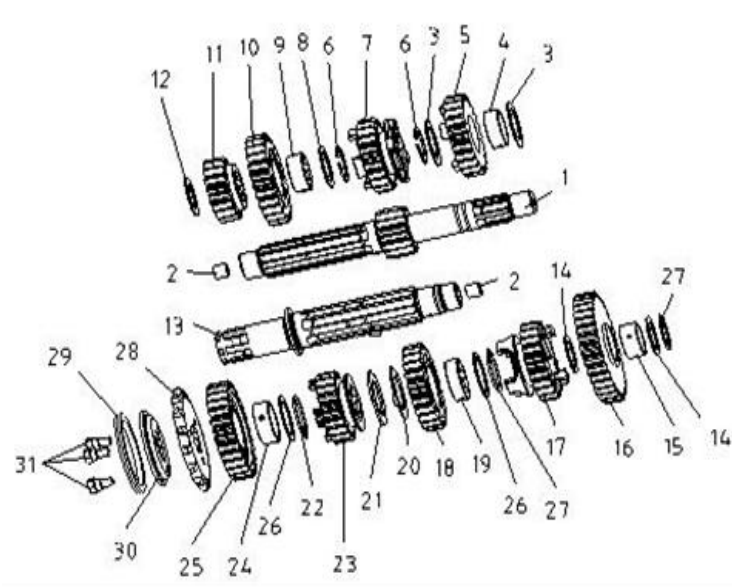

NO.	PART NO..	DESCRIPTION			
E-13-1	14302-F02-0000	TIMMING CHAIN			
E-13-2	14530-F02-0000	TENTIONER COMP.			
E-13-3	GB\T70.1-2000	BOLT M6*25			
E-13-4	90622-F02-0000	WASHER			
E-13-5	14551-F02-0000	GASKET,TENTIONER			
E-13-6	1451A-F02-0000	TENTIONER PLATE, TIMMING CHAIN			
E-13-7	14501-F02-0000	FIXTURE BOLT, TENTIONER PLATE			
E-13-8	90625-F02-0000	WASHER 8x14x1			
E-13-9	1452A-F02-0000	GUIDE PLAT, TIMMING CHAIN			
E-13-10	90501-F02-0000	SCREW M6*9.5			
E-13-11	90623-F02-0000	WASHER			